



COMMONWEALTH OF KENTUCKY
TRANSPORTATION CABINET

www.transportation.ky.gov/

Andy Beshear
GOVERNOR

Jim Gray
SECRETARY

September 11, 2020

CALL NO. 300
CONTRACT ID NO. 201030
ADDENDUM # 1

Subject: MORGAN COUNTY, FE01 088 0460 017-018
Letting September 25, 2020

- (1) Revised - Plan Sheet - Page 12 of 44
- (2) Revised - Special Note for Partial Closure of Parking Area - Page 24 of 44
- (3) Revised - Proposal Bid Items - Page 44 of 44

Proposal revisions are available at <http://transportation.ky.gov/Construction-Procurement/>.

If you have any questions, please contact us at 502-564-3500.

Sincerely,

A handwritten signature in black ink that reads "Rachel Mills".

Rachel Mills, P.E.
Director
Division of Construction Procurement

RM:mr
Enclosures

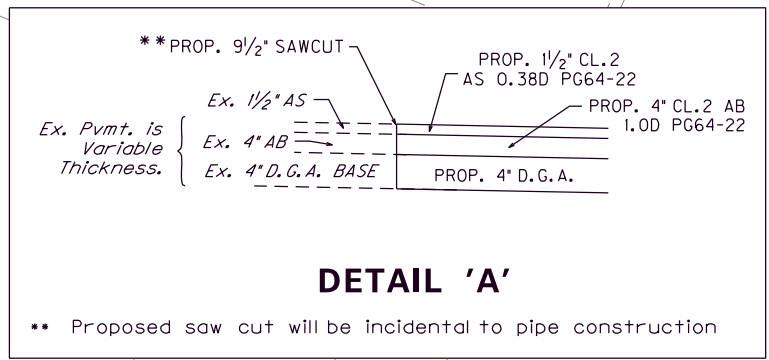
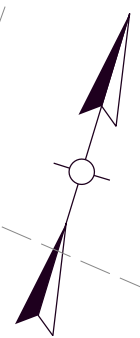

SPECIAL NOTE FOR PARTIAL CLOSURE OF PARKING AREA

**MORGAN COUNTY
West Liberty Drainage Repair
Item No. 10-293
Prestonsburg St. US 460 / KY 7**

A consent & release has been signed for work off KYTC right of way. Conditions of the consent & release are that the contractor shall be permitted to close only the work area to traffic for no more than seven (7) calendar days. The area may be opened to traffic without final asphalt surface and striping.

FOR EACH CALENDAR DAY THAT A PORTION OF THE PARKING LOT IS CLOSED BEYOND THE 7 CALENDAR DAYS GIVEN TO COMPLETE THE WORK, THE DEPARTMENT WILL ASSESS LIQUIDATED DAMAGES AT A RATE OF \$500 PER CALENDAR DAY.

PROPOSAL BID ITEMS

Report Date 9/11/20

Section: 0001 - ROADWAY

LINE	BID CODE	ALT	DESCRIPTION	QUANTITY	UNIT	UNIT PRIC	FP	AMOUNT
0010	00001		DGA BASE	38.00	TON		\$	
0020	00020		TRAFFIC BOUND BASE	20.00	TON		\$	
0030	00212		CL2 ASPH BASE 1.00D PG64-22	36.00	TON		\$	
0040	00301		CL2 ASPH SURF 0.38D PG64-22	24.00	TON		\$	
0050	00356		ASPHALT MATERIAL FOR TACK	.10	TON		\$	
0060	00524		STORM SEWER PIPE-24 IN	12.00	LF		\$	
0070	00528		STORM SEWER PIPE-36 IN (REVISED: 9-11-20)	70.00	LF		\$	
0080	01646		JUNCTION BOX-42 IN	1.00	EACH		\$	
0090	01767		MANHOLE TYPE C	1.00	EACH		\$	
0100	02014		BARRICADE-TYPE III	2.00	EACH		\$	
0110	02483		CHANNEL LINING CLASS II	100.00	TON		\$	
0120	02562		TEMPORARY SIGNS	150.00	SQFT		\$	
0130	02607		FABRIC-GEOTEXTILE CLASS 2 FOR PIPE	457.00	SQYD	\$2.00	\$	\$914.00
0140	02650		MAINTAIN & CONTROL TRAFFIC	1.00	LS		\$	
0150	02701		TEMP SILT FENCE	100.00	LF		\$	
0160	02726		STAKING	1.00	LS		\$	
0170	05963		INITIAL FERTILIZER	.10	TON		\$	
0180	05985		SEEDING AND PROTECTION	300.00	SQYD		\$	
0190	06514		PAVE STRIPING-PERM PAINT-4 IN	300.00	LF		\$	
0200	08100		CONCRETE-CLASS A	2.00	CUYD		\$	

Section: 0002 - DEMOBILIZATION &/OR MOBILIZATION

LINE	BID CODE	ALT	DESCRIPTION	QUANTITY	UNIT	UNIT PRIC	FP	AMOUNT
0210	02569		DEMOBILIZATION	1.00	LS		\$	